

CSSTA

STAINLESS STEEL WELDING FITTINGS

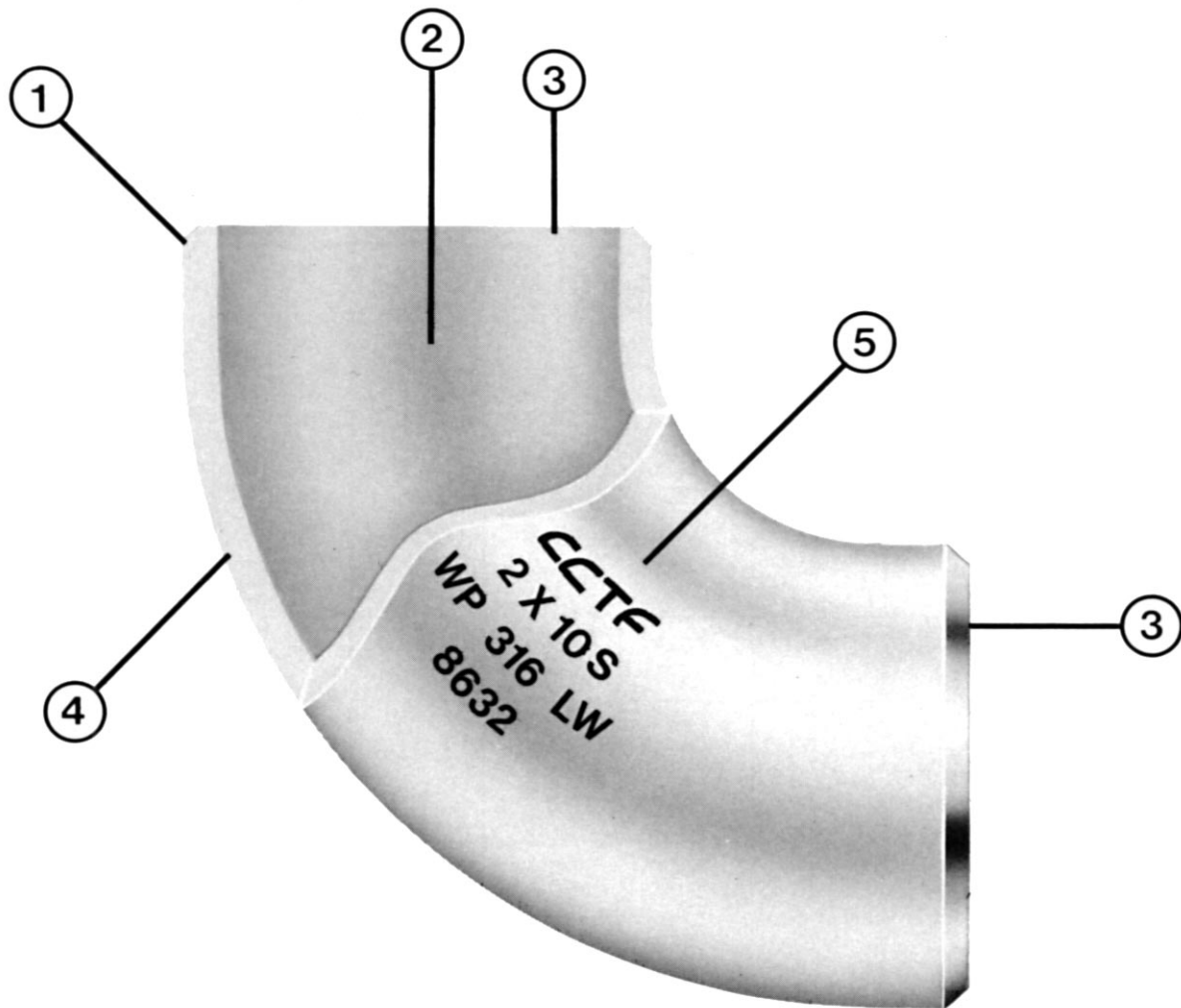

INCHES/METRIC



1. Bevels and lands accurately machined for good welding.
2. True diameter maintained throughout the smooth bore for unrestricted flow.
3. Ends are true and square.
4. Full, uniform wall thickness for maximum strength.
5. Clear identification of size, schedule or nominal wall thickness, material and heat code.

Other types and sizes of STAINLESS STEEL WELDING FITTINGS than those shown in this catalogue may be supplied upon request.

STAINLESS STEEL WELDING FITTINGS INDEX



90° Elbows, Long Radius
Schedules 5S, 10S, 40S, 80S.....Page 6



90° Elbows, Short Radius
Schedules 5S, 10S, 40S, 80S.....Page 7



45° Elbows, Long Radius
Schedules 5S, 10S, 40S, 80S.....Page 8



Tees, Straight and Reducing
Schedules 5S, 10S, 40S, 80S.....Page 9



Reducers, Concentric and Eccentric
Schedules 5S, 10S, 40S, 80S.....Page 12



Caps
Schedules 5S, 10S, 40S, 80S.....Page 14



Lap Joint, Stub Ends
Schedules 10S, 40S — Type A and Type B.....Page 15

Chemical and Mechanical Properties.....Page 4

Welding Bevels.....Page 4

Tolerances.....Page 5

Stainless Steel Pipe Dimensions, ANSI B36.19.....Page 16

MATERIAL AND MANUFACTURING SPECIFICATIONS

CCTF Stainless Steel Welding Fittings are manufactured in accordance with the material specifications of ASTM A-403.

This chart gives the Mechanical and Chemical properties of some of the most widely used alloys.

ANSI Pressure Fittings	Corrosion Resistant Fittings	Mechanical			*Chemical									
		Tensile Strength KSI min. (MPa min.)	Yield Strength KSI min. (MPa min.)	El. 2in. 50mm % Longt.	C	Mn	P	S	SI	Ni	Cr	Mo	Ti	Co
WP 304	CR 304	75 (515)	30 (205)	35	.08	2.0	0.45	0.30	1.00	8.0-11.0	18.0-20.0			
WP 304H	CR 304H	75 (515)	30 (205)	35	.04-1.0	2.0	0.45	.030	1.00	8.0-11.0	18.0-20.0			
WP 304L	CR 304L	70 (485)	25 (170)	35	.035 ^a	2.0	.045	.030	1.00	8.0-13.0	18.0-20.0			
WP 316	CR 316	75 (515)	30 (205)	35	.08	2.0	0.45	.030	1.00	10.0-14.0	16.0-18.0	2.0-3.0		
WP 316H	CR 316H	75 (515)	30 (205)	35	.04-.10	2.0	0.45	.030	1.00	10.0-14.0	16.0-18.0	2.0-3.0		
WP 316L	CR 316L	70 (485)	25 (170)	35	.035 ^a	2.0	.045	.030	1.00	10.0-16.0	16.0-18.0	2.0-3.0		
WP 321	CR 321	75 (515)	30 (205)	35	.08	2.0	0.45	.030	1.00	9.0-13.0	17.0-20.0		e	
WP 321H	CR 321H	75 (515)	30 (205)	35	.04-.10	2.0	0.45	.030	1.00	9.0-13.0	17.0-20.0		c	
WP 347	CR 347	75 (515)	30 (205)	35	.08	2.0	0.45	.030	1.00	9.0-13.0	17.0-20.0			a
WP 347H	CR 347H	75 (515)	30 (205)	35	.04-.10	2.0	0.45	.030	1.00	9.0-13.0	17.0-20.0			b

* Maximum values except as indicated.

See appropriate spec. for exact values.

e The titanium content shall not be less than five times the carbon content and not more than .70 per cent.

a The columbium plus tantalum content shall not be less than ten times the carbon content and not more than 1.10 per cent.

c The titanium content shall not be less than four times the carbon content and not more than .70 per cent.

b The columbium plus tantalum content shall not be less than eight times the carbon content and not more than 1.0 per cent.

d For small diameter or thin walls or both, where many drawing passes are required, a carbon maximum of .040 per cent is necessary in grades WP 304L and WP 316L. Small outside diameter tubes are defined as those less than .500 in. (12.7 mm) in outside diameter and light wall tubes as those less than .049 in. (1.24 mm) in average wall thickness (.044 in. (1.12mm) in minimum wall thickness).

For the appropriate grade of stainless steel for use with corrosive liquids and gases at various temperatures and pressures, consult your nearest CCTF office.

CCTF Stainless Steel Welding Fittings also conform with one or more of the following standards:

MSS SP-43 Schedules 5s and 10s only

ASME/ANSI B16.9 Welding Fittings, except short radius

ASME/ANSI B36.19M Stainless Steel Pipe

ASME/ANSI B16.28 Short Radius Elbows and Returns

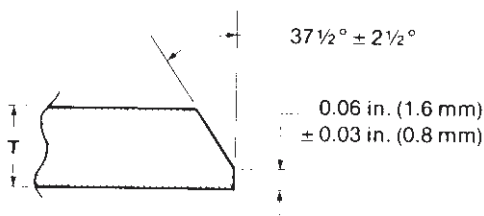

Welding Bevel for "T"
in excess of 0.12 in. (3.2 mm)

WELDING BEVEL MSS SP-43

Fittings furnished to this standard may be finished with ends cut square for wall thicknesses 0.12in. (3.2 mm) or less. For wall thicknesses in excess of 0.12 in. (3.2 mm), they shall be beveled at 37 1/2° plus or minus 2 1/2°; with root face (land) 0.06 in. (1.6 mm) plus or minus 0.03 in. (0.8 mm).

MATERIAL AND MANUFACTURING SPECIFICATIONS

The International System (SI) metric equivalent of British units are shown throughout this catalogue.

NPS (Nominal Pipe Size) = DN*, (Nominal Diameter)
 Operating Pressure Class = PN*, (Pressure Number)
 1 inch = 25.4 millimetres
 1 pound, weight = 0.4536 kilograms
 1 pound, pressure = 0.06895 bars

* From the SI designations, Diamètre Nominal and Pression Nominale

(1) Dimensional Tolerances MSS SP-43

NPS DN	All Fittings		90° & 45° Elbows, Tees, Crosses	Reducers, Lap-Joint Stub Ends	Caps	⁽²⁾ Lap-Joint Stub Ends	
	Outside Dia. at Welding End	Wall Thickness	Centre to End A, B, C, M	Overall Length F, H,	Overall Length E	Fillet Radius of Lap R	Outside Diameter of Lap G
1/2 - 1 1/2	±0.3	Not less than 87 1/2% of nominal thickness	±0.06	±0.06	±.12	+0 -.03	+0 -.03
15 - 40	±1		±2	±2	±4	+0 -1	+0 -1
2 - 3 1/2	±.03		±0.06	±0.06	±.12	+0 -.03	+0 -.03
50 - 90	±1		±2	±2	±4	+0 -1	+0 -1
4	±.03		±0.06	±0.06	±.12	+0 -.06	+0 -.03
100	±1		±2	±2	±4	+0 -2	+0 -1
5 - 8	±.06 -.03		±0.06	±0.06	±.25	+0 -.06	+0 -.03
125 - 200	+2 -1		±2	±2	±7	+0 -2	+0 -1
10 - 18	+.09 -.03		±0.09	±0.09	±.25	+0 -.06	+0 -.06
250 - 450	+2 -1		±3	±3	±7	+0 -2	+0 -2
20 - 24	+.12 -.03		±0.09	±0.09	±.25	+0 -.06	+0 -.06
500 - 600	+3 -1		±3	±3	±7	+0 -2	+0 -2

(1) The tolerances in this table are based on those of the MSS SP-43 standard. The tolerances specified by ASME/ANSI B16.9 differ slightly. For precise information on the relevant specifications should be referred to.

(2) Refer to page 15.

INCHES
MILLIMETRES



90° ELBOW LONG RADIUS

Schedules 5S, 10S, 40S, 80S
MSS SP-43
ASME/ANSI B16.9

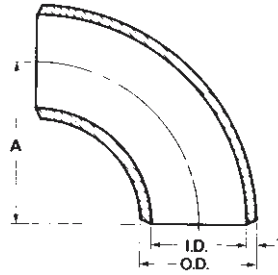

NPS DN	Outside Diameter O.D.	Center To End A	MSS SP-43						ANSI B16.9					
			Schedule 5S			Schedule 10S			Schedule 5S			Schedule 10S		
			Inside Diameter I.D.	Wall Thickness T	Approx. WT.	Inside Diameter I.D.	Wall Thickness T	Approx. WT.	Inside Diameter I.D.	Wall Thickness T	Approx. WT.	Inside Diameter I.D.	Wall Thickness T	Approx. WT.
1/2 15	.84 21	1.50 38	.710 18.00	.065 1.65	.10 .05	.674 17.10	.083 2.10	.13 .06	.622 15.80	.109 2.75	.18 .08	.546 13.90	.147 3.75	.25 .11
3/4 20	1.05 27	*1.12 *29	.920 23.35	.065 1.65	.12 .05	.884 22.45	.083 2.10	.16 .07	.824 20.95	.113 2.85	.19 .09	.742 18.85	.154 3.90	.25 .11
1 25	1.32 33	1.50 38	1.185 30.10	.065 1.65	.22 .1	1.097 27.85	.109 2.75	.38 .17	1.049 26.65	.133 3.40	.40 .18	.957 24.30	.179 4.55	.50 .23
1 1/4 32	1.66 42	1.88 48	1.530 38.85	0.65 1.65	.29 .13	1.442 36.65	.109 2.75	.50 .23	1.380 35.05	.140 3.55	.60 .27	1.278 32.45	.191 4.85	.90 .4
1 1/2 40	1.90 48	2.25 57	1.770 44.95	.065 1.65	.44 .2	1.682 42.70	.109 2.75	.75 .34	1.610 40.90	.145 3.70	.90 .4	1.500 38.10	.200 5.10	1.15 .5
2 50	2.38 60	3.00 76	2.245 57.00	.065 1.65	.66 .3	2.157 54.80	.109 2.75	1.1 .5	2.067 52.50	.154 3.90	1.60 .7	1.939 49.25	.218 5.55	2.2 1
2 1/2 65	2.88 73	3.75 95	2.709 68.80	.083 2.10	1.24 .56	2.635 66.95	.120 3.05	.8 1.8	2.469 62.70	.203 5.15	3.25 1.5	2.323 59.00	.276 7.00	4 1.8
3 80	3.50 89	4.50 114	3.334 84.70	.083 2.10	1.73 .8	3.260 82.80	.120 3.05	2.5 1.1	3.068 77.95	.216 5.50	5.0 2.3	2.900 73.65	.300 7.60	6.5 3
3 1/2 90	4.00 102	5.25 133	3.834 97.40	.083 2.10	2.35 1.1	3.760 95.50	.120 3.05	3.4 1.5	3.548 90.10	.226 5.75	6.75 3	3.364 85.45	.318 8.10	8.4 3.8
4 100	4.50 114	6.00 152	4.334 110.10	.083 2.10	2.97 1.3	4.260 108.20	.120 3.05	4.3 1.9	4.026 102.25	.237 6.00	9 4	3.826 97.20	.337 8.55	13.5 6.1
5 125	5.56 141	7.50 190	5.345 135.75	.109 2.75	6.01 2.7	5.295 134.50	.134 3.40	7.4 3.3	5.047 128.20	.258 6.55	15.5 7	4.813 122.25	.375 9.55	22 10
6 150	6.62 168	9.00 229	6.407 162.75	.109 2.75	8.94 4	6.357 161.50	.134 3.40	11 5	6.065 154.05	.280 7.10	24.5 11	5.761 146.35	.432 10.95	35 15.8
8 200	8.62 219	12.00 305	8.407 213.55	.109 2.75	15.4 6.9	8.329 211.55	.148 3.75	21 9.5	7.981 202.70	.322 8.20	50 22	7.625 193.70	.500 12.70	71 32
10 250	10.75 273	15.00 381	10.482 266.25	.134 3.40	29.2 13.1	10.420 264.70	.165 4.20	36 16	10.020 254.5	.365 9.25	88 40	9.75 247.65	.500 12.70	107 48
12 300	12.75 324	18.00 457	12.420 315.45	.156 3.95	51.2 23	12.390 314.70	.180 4.55	57 26	12.000 304.80	.375 9.55	125 56	11.75 298.45	.500 12.70	160 72

* Centre to end dimension A for NPS 3/4 (DN 20) may be 1.50 (38mm) at the manufacturer's option.

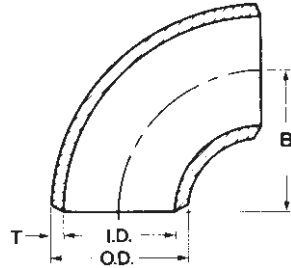

90° ELBOW LONG RADIUS

Schedules 5S, 10S, 40S, 80S
ASME/ANSI B16.28

NPS	Outside Diameter O.D.	Center To End B	Schedule 5S			Schedule 10S			Schedule 40S			Schedule 80S		
			Inside Diameter I.D.	Wall Thickness T	Approx. WT.	Inside Diameter I.D.	Wall Thickness T	Approx. WT.	Inside Diameter I.D.	Wall Thickness T	Approx. WT.	Inside Diameter I.D.	Wall Thickness T	Approx. WT.
1	1.32	1.00	1.185	.065	.12	1.097	.109	.23	1.049	.133	.25	.957	.179	.41
25	33	25	30.10	1.65	.05	27.85	2.75	.1	26.65	3.40	.11	24.30	4.55	.18
1 1/4	1.66	1.25	1.530	.065	.25	1.442	.109	.38	1.380	.140	.40	1.278	.191	.63
32	42	32	38.85	1.65	.11	36.65	2.75	.17	35.05	3.55	.18	32.45	4.85	.28
1 1/2	1.90	1.50	1.770	.065	.42	1.682	.109	.49	1.610	.145	.56	1.500	.200	.75
40	48	38	44.95	1.65	.19	42.70	2.75	.22	40.90	3.70	.25	38.10	5.10	.34
2	2.38	2.00	2.245	.065	.63	2.157	.109	.81	2.067	.154	1	1.939	.218	1.5
50	60	51	57.00	1.65	.28	54.80	2.75	.36	52.50	3.90	.45	49.25	5.55	.68
2 1/2	2.88	2.50	2.709	.083	1.22	2.635	.120	1.36	2.469	.203	2.13	2.323	.276	2.8
65	73	64	68.80	2.10	.55	66.95	3.05	.6	62.70	5.15	.96	59.00	7.00	1.3
3	3.50	3.00	3.334	.083	1.7	3.260	.120	2.17	3.068	.216	3	2.900	.300	4.25
80	89	76	84.70	2.10	.8	82.80	3.05	1.0	77.95	5.50	1.4	73.65	7.60	1.9
3 1/2	4.00	3.50	3.834	.083	2.3	3.760	.120	3.03	3.548	.226	4.5	3.364	.318	6
90	102	89	97.40	2.10	1.0	95.50	3.05	1.4	90.10	5.75	2	85.45	8.10	2.7
4	4.50	4.00	4.334	.083	2.95	4.260	.120	3.8	4.026	.237	6.25	3.826	.337	8.5
100	114	102	100.10	2.10	1.3	108.20	3.05	1.7	102.25	6.00	2.8	97.20	8.55	3.8
5	5.56	5.00	5.345	.109	4.24	5.295	.134	5.19	5.047	.258	9.6	4.813	.375	14
125	141	127	135.75	2.75	1.9	134.50	3.40	2.3	128.20	6.55	4.3	122.25	9.55	6.3
6	6.62	6.00	6.407	.109	6.09	6.357	.134	7.45	6.065	.280	18	5.761	.432	23
150	168	152	162.75	2.75	2.7	161.50	3.40	3.4	154.05	7.10	8.1	146.35	10.95	10.4

INCHES
MILLIMETRES

POUNDS
KILOGRAMS

45° ELBOW LONG RADIUS

Schedules 5S, 10S, 40S, 80S
MSS SP-43
ASME/ANSI B16.9

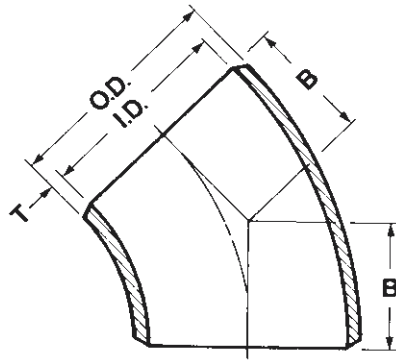

NPS DN	Outside Diameter O.D.	Center To End B	MSS SP-43						ANSI B16.9					
			Schedule 5S			Schedule 10S			Schedule 40S			Schedule 80S		
			Inside Diameter I.D.	Wall Thickness T	Approx. WT.	Inside Diameter I.D.	Wall Thickness T	Approx. WT.	Inside Diameter I.D.	Wall Thickness T	Approx. WT.	Inside Diameter I.D.	Wall Thickness T	Approx. WT.
1/2	.84	.62	.710	.065	.05	.674	.083	.06	.622	.109	.09	.546	.147	.19
15	21	16	18.00	1.65	.02	17.10	2.10	.03	15.80	2.75	.04	13.90	3.75	.09
3/4	1.05	*.44	.920	.065	.06	.884	.083	.08	.824	.113	.09	.742	.154	.19
20	27	*11	23.35	1.65	.03	22.45	2.10	.04	20.95	2.84	.04	18.85	3.90	.09
1	1.32	.88	1.185	.065	.14	1.097	.109	.25	1.049	.133	.25	.957	.179	.31
25	33	22	30.10	1.65	.06	27.85	2.75	.11	26.65	3.40	.11	24.30	4.55	.14
1 1/4	1.66	1.00	1.530	.065	.19	1.442	.109	.33	1.380	.140	.38	1.278	.191	.50
32	42	25	38.85	1.65	.09	36.65	2.75	.15	35.05	3.55	.17	32.45	4.85	.23
1 1/2	1.90	1.12	1.770	.065	.28	1.682	.109	.47	1.610	.145	.40	1.500	.200	.69
40	48	29	44.95	1.65	.13	42.70	2.75	.21	40.90	3.70	.18	38.10	5.10	.31
2	2.38	1.38	2.245	.065	.35	2.157	.109	.60	2.067	.154	.81	1.939	.218	1.19
50	60	35	57.00	1.65	.16	54.80	2.75	.27	52.50	3.90	.36	49.25	5.55	.54
2 1/2	2.88	1.75	2.709	.083	.69	2.635	.120	1.0	2.469	.203	1.75	2.323	.276	2.13
65	73	44	68.80	2.10	.31	66.95	3.05	.45	62.70	5.15	.8	59.00	7.00	.96
3	3.50	2.00	3.334	.083	.89	3.260	.120	1.3	3.068	.216	2.63	2.900	.300	3.5
80	89	51	84.70	2.10	.4	82.80	3.05	.6	77.95	5.50	1.2	73.65	7.60	1.6
3 1/2	4.00	2.25	3.834	.083	1.17	3.760	.120	1.7	3.548	.226	3.5	3.364	.318	4.5
90	102	57	97.40	2.10	.53	95.50	3.05	.77	90.10	5.75	1.6	85.45	8.10	2
4	4.50	2.50	4.334	.083	1.52	4.260	.120	2.2	4.026	.237	4.5	3.826	.337	6.1
100	114	64	110.10	2.10	.68	108.20	3.05	1	102.25	6.00	2	97.20	8.55	2.8
5	5.56	3.12	5.345	.109	3.09	5.295	.134	3.8	5.047	.258	7.5	4.813	.375	10.7
125	141	79	135.75	2.75	1.4	134.50	3.40	1.7	128.20	6.55	3.4	122.25	9.55	4.8
6	6.62	3.75	6.407	.109	4.5	6.357	.134	5.5	6.065	.280	12	5.761	.432	17.5
150	168	95	162.75	2.75	2	161.50	3.40	2.5	154.05	7.10	5.4	146.35	10.95	7.9
8	8.62	5.00	8.407	.109	8.1	8.329	.148	11	7.981	.322	23	7.625	.500	35
200	219	127	213.55	2.75	3.7	211.55	3.75	5	202.70	8.20	10.4	193.70	12.70	15.8
10	10.75	6.25	10.482	.134	14.6	10.420	.165	18	10.020	.365	43	9.75	.500	53
250	273	159	266.25	3.40	6.6	264.70	4.20	8	254.50	9.25	19.4	247.65	12.70	23.9
12	12.75	7.50	12.420	.156	25.5	12.390	.180	29	12.000	.375	62	11.75	.500	84
300	324	190	315.45	3.95	11.5	314.70	4.55	13	304.80	9.55	28	298.45	12.70	38

* Centre to end dimension B for NPS 3/4 (DN 20) may be 0.75 (19mm) at the manufacturer's option.

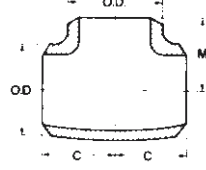
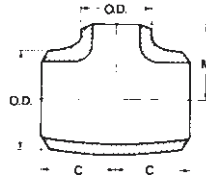

STRAIGHT & REDUCING TEES

Schedules 5S, 10S, 40S, 80S
MSS SP-43
ASME/ANSI B.16.9

NPS	DN	O.D. Outside Dia. Run	O.D. Outside Dia. Outlet	Centre to End		Approximate Weight			
				C	M	MSS SP-43		ANSI B16.9	
						SCH. 5S	SCH. 10S	SCH. 40S	SCH. 80S
1/2 straight		.84	.84	1.00	1.00	.18	.20	.35	.45
	15 straight	21	21	25	25	.08	.09	.16	.2
3/4 x 3/4 x 1/2		1.05	.84	1.12	1.12	.25	.28	.5	.5
	20 x 20 x 15	27	21	29	29	.11	.13	.23	.23
3/4 straight		1.05	1.05	1.12	1.12	.21	.28	.45	.6
	20 straight	27	27	29	29	.09	.13	.20	.27
1 x 1 x 1/2		1.32	.84	1.50	1.50	.43	.56	.88	1
	25 x 25 x 15	33	21	38	38	.19	.25	.40	.45
1 x 1 x 3/4		1.32	1.05	1.50	1.50	.46	.60	.93	1
	25 x 25 x 20	33	27	38	38	.21	.27	.42	.45
1 straight		1.32	1.32	1.50	1.50	.35	.60	.75	.88
	25 straight	33	33	38	38	.16	.27	.34	.40
1 1/4 x 1 1/4 x 1/2		1.66	.84	1.88	1.88	.65	1.06	1.5	1.75
	32 x 32 x 15	42	21	48	48	.29	.48	.68	.79
1 1/4 x 1 1/4 x 3/4		1.66	1.05	1.88	1.88	.67	1.1	1.5	1.75
	32 x 32 x 20	42	27	48	48	.30	.50	.68	.79
1 1/4 x 1 1/4 x 1		1.66	1.32	1.88	1.88	.69	1.15	1.5	1.75
	32 x 32 x 25	42	33	48	48	.31	.52	.68	.79
1 1/4 straight		1.66	1.66	1.88	1.88	.65	1.1	1.3	1.6
	32 straight	42	42	48	48	.29	.50	.59	.72
1 1/2 x 1 1/2 x 1/2		1.90	.84	2.25	2.25	.79	1.33	2	2.5
	40 x 40 x 15	48	21	57	57	.36	.60	.9	1.1
1 1/2 x 1 1/2 x 3/4		1.90	1.05	2.25	2.25	.84	1.41	2.13	2.5
	40 x 40 x 20	48	27	57	57	.38	.63	.96	1.1
1 1/2 x 1 1/2 x 1		1.90	1.32	2.25	2.25	.86	1.45	2.18	2.5
	40 x 40 x 25	48	33	57	57	.39	.65	.98	1.1
1 1/2 x 1 1/2 x 1 1/4		1.90	1.66	2.25	2.25	.89	1.50	2.25	2.5
	40 x 40 x 32	48	42	57	57	.40	.68	1.0	1.1
1 1/2 straight		1.90	1.90	2.25	2.25	.89	1.5	2	2.25
	40 straight	48	48	57	57	.40	.68	.9	1.0
2 x 2 x 3/4		2.38	1.05	2.50	1.75	.93	1.37	3.25	4
	50 x 50 x 20	60	27	64	44	.42	.62	1.46	1.8
2 x 2 x 1		2.38	1.32	2.50	2.00	1.0	1.67	3.50	4.1
	50 x 50 x 25	60	33	64	51	.45	.75	1.58	1.9

Continued on page 10...
For wall thicknesses, refer to page 16.

INCHES
MILLIMETRES

POUNDS
KILOGRAMS



STRAIGHT & REDUCING TEES continued

NPS DN	Outside Dia. Run	Outside Dia. Outlet	Centre to End		Approximate Weight			
			C	M	MSS SP-43		ANSI B16.9	
					SCH. 5S	SCH. 10S	SCH. 40S	SCH. 80S
2 x 2 x 1 1/4	2.38	1.66	2.50	2.25	1.02	1.72	3.6	4.13
50 x 50 x 32	60	42	64	57	.5	.8	1.6	1.9
2 x 2 x 1 1/2	2.38	1.90	2.50	2.38	1.07	1.8	3.75	4.25
50 x 50 x 40	60	48	64	60	.5	.8	1.7	1.9
2 straight	2.38	2.38	2.50	2.50	1.07	1.8	3.5	4
50 straight	60	60	64	64	.5	.8	1.6	1.8
2 1/2 x 2 1/2 x 1	2.88	1.32	3.00	2.25	1.48	2.49	5	7
65 x 65 x 25	73	33	76	57	.7	1.1	2.3	3.2
2 1/2 x 2 1/2 x 1 1/4	2.88	1.66	3.00	2.50	1.55	2.62	5.25	7.06
65 x 65 x 32	73	42	76	64	.7	1.2	2.4	3.2
2 1/2 x 2 1/2 x 1 1/2	2.88	1.90	3.00	2.62	1.63	2.74	5.5	7.13
65 x 65 x 40	73	48	76	67	.7	1.2	2.5	3.2
2 1/2 x 2 1/2 x 2	2.88	2.38	3.00	2.75	1.78	3	6	7.19
65 x 65 x 50	73	60	76	70	.8	1.4	2.7	3.2
2 1/2 straight	2.88	2.88	3.00	3.00	2.07	3	6	7
65 straight	73	73	76	76	.9	1.4	2.7	3.2
3 x 3 x 1 1/4	3.50	1.66	3.38	2.75	2.47	3.61	6.25	7.6
80 x 80 x 32	89	42	86	70	1.1	1.6	2.8	3.4
3 x 3 x 1 1/2	3.50	1.90	3.38	2.88	2.47	3.65	6.25	7.68
80 x 80 x 40	89	48	86	73	1.1	1.6	2.8	3.5
3 x 3 x 2	3.50	2.38	3.38	3.00	2.57	3.75	6.5	8
80 x 80 x 50	89	60	86	76	1.2	1.7	2.9	3.6
3 x 3 x 2 1/2	3.50	2.88	3.38	3.25	2.69	3.9	6.75	8.25
80 x 80 x 65	89	73	86	83	1.2	1.8	3	3.7
3 straight	3.50	3.50	3.38	3.38	2.69	3.9	7	8.5
80 straight	89	89	86	86	1.2	1.8	3.2	3.8
3 1/2 x 3 1/2 x 1 1/2	4.00	1.90	3.75	3.12	3.08	4.2	8	11.5
90 x 90 x 40	102	48	95	79	1.4	1.9	3.6	5.2
3 1/2 x 3 1/2 x 2	4.00	2.38	3.75	3.25	3.19	4.49	8.3	11.8
90 x 90 x 50	102	60	95	83	1.4	2	3.7	5.3
3 1/2 x 3 1/2 x 2 1/2	4.00	2.88	3.75	3.50	3.26	4.73	8.5	12.2
90 x 90 x 65	102	73	95	89	1.5	2.1	3.8	5.5
3 1/2 x 3 1/2 x 3	4.00	3.50	3.75	3.62	3.38	4.9	8.8	12.6
90 x 90 x 80	102	89	95	92	1.5	2.2	4	5.7
3 1/2 straight	4.00	4.00	3.75	3.75	3.38	4.9	9	12
90 straight	102	102	95	95	1.5	2.2	4	5.4
4 x 4 x 1 1/2	4.50	1.90	4.12	3.38	3.7	5.38	11.1	15.2
100 x 100 x 40	114	48	105	86	1.7	2.4	5	6.8
4 x 4 x 2	4.50	2.38	4.12	3.50	3.75	5.43	11.2	15.5
100 x 100 x 50	114	60	105	89	1.7	2.4	5	7
4 x 4 x 2 1/2	4.50	2.88	4.12	3.75	3.77	5.45	11.3	15.5
100 x 100 x 65	114	73	105	95	1.7	2.5	5.1	7
4 x 4 x 3	4.50	3.50	4.12	3.88	3.88	5.6	11.6	15.6
100 x 100 x 80	114	89	105	98	1.8	2.5	5.2	7
4 x 4 x 3 1/2	4.50	4.00	4.12	4.00	3.94	5.7	11.8	15.6
100 x 100 x 90	114	102	105	102	1.8	2.6	5.3	7
4 straight	4.50	4.50	4.12	4.12	3.94	5.7	12	15.7
100 straight	114	114	105	105	1.8	2.6	5.4	7.1

Continued on page 11...

For wall thicknesses, refer to page 16.

INCHES
MILLIMETRES

POUNDS
KILOGRAMS

STRAIGHT & REDUCING TEES continued

NPS	DN	Outside Dia. Run	Outside Dia. Outlet	Centre to End		Approximate Weight			
				C	M	MSS SP-43		ANSI B16.9	
						SCH. 5S	SCH. 10S	SCH. 40S	SCH. 80S
5 x 5 x 2		5.56	2.38	4.88	4.12	7.52	10.8	19	23.5
	125 x 125 x 50	141	60	124	105	3.4	4.9	8.6	10.6
5 x 5 x 2 1/2		5.56	2.88	4.88	4.25	7.7	11.1	19.5	24
	125 x 125 x 65	141	73	124	108	3.5	5	8.8	10.8
5 x 5 x 3		5.56	3.50	4.88	4.38	7.91	11.4	20	24.5
	125 x 125 x 80	141	89	124	111	3.6	5.1	9	11
5 x 5 x 3 1/2		5.56	4.00	4.88	4.50	8.1	11.7	20.5	25
	125 x 125 x 90	141	102	124	114	3.7	5.3	9.2	11.3
5 x 5 x 4		5.56	4.50	4.88	4.62	8.29	12	21	25.5
	125 x 125 x 100	141	114	124	117	3.7	5.4	9.5	11.5
5 straight		5.56	5.56	4.88	4.88	9.76	12	21	26
	125 straight	141	141	124	124	4.4	5.4	9.5	11.7
6 x 6 x 2 1/2		6.62	2.88	5.62	4.75	12.7	15.7	32	36
	150 x 150 x 65	168	73	143	121	5.7	7.1	14.4	16.2
6 x 6 x 3		6.62	3.50	5.62	4.88	12.9	16	32.5	37
	150 x 150 x 80	168	89	143	124	5.8	7.2	14.6	16.7
6 x 6 x 3 1/2		6.62	4.00	5.62	5.00	13.1	16.2	33	38.2
	150 x 150 x 90	168	102	143	127	5.9	7.3	14.9	17.2
6 x 6 x 4		6.62	4.50	5.62	5.12	13.3	16.5	33.5	39.2
	150 x 150 x 100	168	114	143	130	6	7.4	15	17.6
6 x 6 x 5		6.62	5.56	5.62	5.38	13.8	17	34.5	40
	150 x 150 x 125	168	141	143	137	6.2	7.7	15.5	18
6 straight		6.62	6.62	5.62	5.62	13.8	17	34	40
	150 straight	168	168	143	143	6.2	7.7	15.3	18
8 x 8 x 3 1/2		8.62	4.00	7.00	6.00	19	23.4	50.7	70.5
	200 x 200 x 90	219	102	178	152	8.6	10.5	22.8	31.7
8 x 8 x 4		8.62	4.50	7.00	6.12	19.4	23.9	51.7	71.7
	200 x 200 x 100	219	114	178	156	8.7	10.8	23.3	32.3
8 x 8 x 5		8.62	5.56	7.00	6.38	19.9	24.5	53	73
	200 x 200 x 125	219	141	178	162	9	11	23.9	32.9
8 x 8 x 6		8.62	6.62	7.00	6.62	20.3	25	54	74
	200 x 200 x 150	219	168	178	168	9.1	11.3	24.3	33.3
8 straight		8.62	8.62	7.00	7.00	18.4	25	55	75
	200 straight	219	219	178	178	8.3	11.3	24.8	33.8
10 x 10 x 6		10.75	6.62	8.50	7.62	26.7	36.3	83	108
	250 x 250 x 150	273	168	216	194	12	16.3	37.4	48.6
10 x 10 x 8		10.75	8.62	8.50	8.00	27.2	37	84.5	109
	250 x 250 x 200	273	219	216	203	12.2	16.7	38	49
10 straight		10.75	10.75	8.50	8.50	30	37	85	105
	250 straight	273	273	216	216	14	16.7	38.3	47.3
12 x 12 x 6		12.75	6.62	10.00	8.62	39.6	51.7	114	165
	300 x 300 x 150	324	168	254	219	17.8	23.3	51	74.3
12 x 12 x 8		12.75	8.62	10.00	9.00	40.6	53	117	175
	300 x 300 x 250	324	273	254	241	18.6	24.3	53.6	83.3
12 x 12 x 10		12.75	10.75	10.00	9.50	41.4	54	119	185
	300 x 300 x 250	324	273	254	241	18.6	24.3	53.6	83.3
12 straight		12.75	12.75	10.00	10.00	46.7	54	120	160
	300 straight	324	324	254	254	21	24.3	54	72

INCHES
MILLIMETRES

POUNDS
KILOGRAMS

For wall thicknesses, refer to page 16.

REDUCERS CONCENTRIC & ECCENTRIC

Schedules 5S, 10S, 40S, 80S
ASME/ANSI B16.9
MSS SP-43

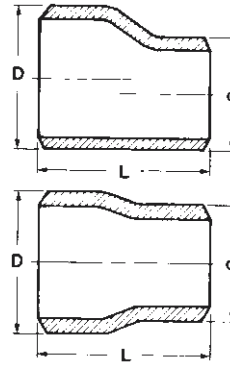

NPS DN	Length L	Outside Diameter		Approximate Weight			
		Large End D	Small End d	MSS SP-43		ANSI B16.9	
				SCH. 5S	SCH. 10S	SCH. 40S	SCH. 80S
3/4 x 1/2 20 x 15	1.5 38	1.05 27	.84 21	.1 .05	.16 .07	.17 .08	.22 .1
1 x 1/2 25 x 15	2 51	1.32 33	.84 21	.2 .09	.37 .17	.40 .18	.45 .2
1 x 3/4 25 x 20	2 51	1.32 33	1.05 27	.21 .09	.38 .17	.40 .18	.45 .2
1 1/4 x 1/2 32 x 15	2 51	1.66 42	.84 21	.23 .1	.39 .18	.40 .18	.50 .23
1 1/4 x 3/4 32 x 20	2 51	1.66 42	1.05 27	.24 .11	.42 .19	.40 .18	.50 .23
1 1/4 x 1 32 x 25	2 51	1.66 42	1.32 33	.25 .11	.44 .2	.50 .23	.50 .23
1 1/2 x 1/2 40 x 15	2.5 64	1.90 48	.84 21	.24 .11	.49 .22	.50 .23	.65 .3
1 1/2 x 3/4 40 x 20	2.5 64	1.90 48	1.05 27	.26 .12	.53 .24	.54 .24	.70 .32
1 1/2 x 1 40 x 25	2.5 64	1.90 48	1.32 33	.28 .13	.56 .25	.62 .28	.75 .34
1 1/2 x 1 1/4 40 x 32	2.5 64	1.90 48	1.66 42	.32 .14	.59 .27	.70 .32	.78 .35
2 x 3/4 50 x 20	3 76	2.38 60	1.05 27	.29 .13	.71 .32	.70 .32	1.0 .45
2 x 1 50 x 25	3 76	2.38 60	1.32 33	.32 .14	.78 .35	.76 .34	1.1 .5
2 x 1 1/4 50 x 32	3 76	2.38 60	1.66 42	.36 .16	.82 .37	.84 .38	1.15 .62
2 x 1 1/2 50 x 40	3 76	2.38 60	1.90 48	.38 .17	.85 .38	.90 .41	1.2 .54
2 1/2 x 1 65 x 25	3.5 89	2.88 73	1.32 33	.51 .23	1.04 .47	1.25 .56	1.75 .79
2 1/2 x 1 1/4 65 x 32	3.5 89	2.88 73	1.66 42	.54 .24	1.09 .49	1.25 .56	1.85 .83
2 1/2 x 1 1/2 65 x 40	3.5 89	2.88 73	1.90 48	.57 .26	1.12 .5	1.38 .62	1.9 .86
2 1/2 x 2 65 x 50	3.5 89	2.88 73	2.38 60	.62 .28	1.18 .53	1.50 .68	2 .9
3 x 1 1/4 80 x 32	3.5 89	3.50 89	1.66 42	.62 .28	1.33 .62	1.6 .72	2.4 1.1
3 x 1 1/2 80 x 40	3.5 89	3.50 89	1.90 48	.66 .3	1.39 .63	1.7 .77	2.5 1.13
3 x 2 80 x 50	3.5 89	3.50 89	2.38 60	.69 .31	1.45 .29	1.8 .8	2.6 1.17
3 x 2 1/2 80 x 65	3.5 89	3.50 89	2.88 73	.76 .34	1.53 .69	2 .9	2.75 1.24
3 1/2 x 1 1/2 90 x 40	4.0 102	4.00 102	1.90 48	.94 .42	1.73 .78	2.5 1.13	3.25 1.46

Continued on page 13...

For wall thicknesses and inside diameters refer to page 16.

REDUCERS CONCENTRIC & ECCENTRIC continued

NPS DN	Length L	Outside Diameter		Approximate Weight			
		Large End D	Small End d	MSS SP-43		ANSI B16.9	
				SCH. 5S	SCH. 10S	SCH. 40S	SCH. 80S
3 1/2 x 2	4.0	4.00	2.38	1.04	1.86	2.75	3.5
90 x 50	102	102	60	.47	.84	1.24	1.6
3 1/2 x 2 1/2	4.0	4.00	2.88	1.09	1.96	2.88	3.5
90 x 65	102	102	73	.49	.88	1.3	1.6
3 1/2 x 3	4.0	4.00	3.50	1.19	2.12	3.15	4
90 x 80	102	102	89	.54	.95	1.42	1.8
4 x 1 1/2	4.0	4.50	1.90	1.02	2.06	2.88	4
100 x 40	102	114	48	.46	.93	1.3	1.8
4 x 2	4.0	4.50	2.38	1.05	2.16	3	4.25
100 x 50	102	114	60	.47	.97	1.35	1.9
4 x 2 1/2	4.0	4.50	2.88	1.15	2.22	3.25	4.38
100 x 65	102	114	73	.52	1.0	1.46	2
4 x 3	4.0	4.50	3.50	1.19	2.28	3.38	4.5
100 x 80	102	114	89	.54	1.03	1.52	2
4 x 3 1/2	4.0	4.50	4.00	1.23	2.41	3.5	4.75
100 x 90	102	114	102	.55	1.08	1.58	2.14
5 x 2	5.0	5.56	2.38	2.12	3.35	5	6.5
125 x 50	127	141	60	.95	1.5	2.3	2.9
5 x 2 1/2	5.0	5.56	2.88	2.22	3.64	5.25	7
125 x 65	127	141	73	1.0	1.64	2.36	3.15
5 x 3	5.0	5.56	3.50	2.33	3.90	5.5	7.5
125 x 80	127	141	89	1.05	1.76	2.48	3.38
5 x 3 1/2	5.0	5.56	4.00	2.44	4.03	5.75	7.75
125 x 90	127	141	102	1.1	1.8	2.59	3.5
5 x 4	5.0	5.56	4.50	2.54	4.29	6	8.25
125 x 100	127	141	114	1.14	1.93	2.7	3.7
6 x 2 1/2	5.5	6.62	2.88	2.83	4.79	7.25	10
150 x 65	140	168	73	1.27	2.16	3.26	4.5
6 x 3	5.5	6.62	3.50	3.12	5.04	8	10.5
150 x 80	140	168	89	1.4	2.27	3.6	4.7
6 x 3 1/2	5.5	6.62	4.00	3.22	5.28	8.25	11
150 x 90	140	168	102	1.45	2.38	3.7	5
6 x 4	5.5	6.62	4.50	3.27	5.52	8.25	11.5
150 x 100	140	168	114	1.47	2.48	3.7	5.2
6 x 5	5.5	6.62	5.56	3.31	5.76	8.5	12
150 x 125	140	168	141	1.5	2.59	3.8	5.4
8 x 3 1/2	6.0	8.62	4.00	3.8	6.9	11	16.5
200 x 90	140	219	102	1.7	3.1	5	7.4
8 x 4	6.0	8.62	4.50	3.95	7.1	11	17
200 x 100	152	219	114	1.78	3.2	5	7.65
8 x 5	6.0	8.62	5.56	4.06	7.51	12	18
200 x 125	152	219	141	1.83	3.38	5.4	8
8 x 6	6.0	8.62	6.62	4.46	7.8	13.2	18.7
200 x 150	152	219	168	2	3.5	5.9	8.4
10 x 4	7.0	10.75	4.50	7.34	10.5	20	25.5
250 x 100	178	273	114	3.3	4.7	9	11.5
10 x 5	7.0	10.75	5.56	7.71	12.6	21	28
250 x 125	178	273	141	3.5	5.7	9.5	12.6
10 x 6	7.0	10.75	6.62	7.89	13.3	21.5	29.5
250 x 150	178	273	168	3.55	6.0	9.7	13.3
10 x 8	7.0	10.75	8.62	8.08	14	22	29.5
250 x 200	178	273	219	3.64	6.3	9.9	13.3
12 x 5	8.0	12.75	5.56	12.9	18.7	30	39
300 x 125	203	324	141	5.8	8.4	13.5	17.6
12 x 6	8.0	12.75	6.62	12.9	19.2	31	40
300 x 150	203	324	168	5.8	8.6	14	18
12 x 8	8.0	12.75	8.62	13.4	20.4	32	42
300 x 200	203	324	219	6.03	9.2	14.4	19
12 x 10	8.0	12.75	10.75	14.1	20.9	34	43.5
300 x 250	203	324	273	6.35	9.4	15.3	19.6

For wall thicknesses and inside diameters refer to page 16.

INCHES	POUNDS
MILLIMETRES	KILOGRAMS

CAPS ▲

Schedules 5S, 10S, 40S, 80S
MSS SP-43
ASME/ANSI B16.9

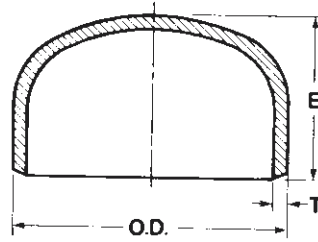

NPS DN	Outside Diameter O.D.	Length E	MSS SP-43				ANSI B16.9			
			Schedule 5S		Schedule 10S		Schedule 40S		Schedule 80S	
			Wall Thickness T	Approx. WT.	Wall Thickness T	Approx. WT.	Wall Thickness T	Approx. WT.	Wall Thickness T	Approx. WT.
1/2	.84	1.00	.065	.08	.083	.09	.109	.10	.147	.11
15	21	25	1.65	.04	2.10	.04	2.75	.05	3.75	.05
3/4	1.05	1.00	.065	.11	.083	.12	.113	.13	.154	.14
20	.27	25	1.65	.05	2.10	.05	2.85	.06	3.90	.06
1	1.32	1.50	.065	.18	.109	.19	.133	.28	.179	.3
25	33	38	1.65	.08	2.75	.09	3.40	.13	4.55	.14
1 1/4	1.66	1.50	.065	.20	.109	.28	.140	.38	.191	.4
32	42	38	1.65	.09	2.75	.13	3.55	.17	4.85	.18
1 1/2	1.90	1.50	.065	.22	.109	.31	.145	.5	.200	.54
40	48	38	1.65	.1	2.75	.14	3.70	.23	5.10	.24
2	2.38	1.50	.065	.36	.109	.38	.154	.6	.218	.75
50	60	38	1.65	.16	2.75	.17	3.90	.27	5.55	.34
2 1/2	2.88	1.50	.083	.50	.120	.56	.203	1.0	.276	1.1
65	75	38	2.10	.23	3.05	.25	5.15	.45	7.00	.5
3	3.50	2.00	.083	.86	.120	.88	.216	1.6	.300	1.9
80	89	51	2.10	.4	3.05	.4	5.50	.72	7.60	.86
3 1/2	4.00	2.50	.083	1.2	.120	1.25	.226	2.3	.318	2.5
90	102	64	2.10	.54	3.05	.56	5.75	1.0	8.10	1.1
4	4.50	2.50	.083	1.25	.120	1.4	.237	2.7	.337	3.5
100	114	64	2.10	.56	3.05	.6	6.00	1.2	8.55	1.6
5	5.56	3.00	.109	2	.134	2.3	.258	4.1	.375	5.6
125	141	76	2.75	.9	3.40	1.0	6.55	1.8	9.55	2.5
6	6.62	3.50	.109	2.75	.134	3	.280	7.1	.432	10
150	168	89	2.75	1.24	3.40	1.4	7.10	3.2	10.95	4.5
8	8.62	4.00	.109	4.5	.148	5.5	.322	12.5	.500	16.4
200	219	102	2.75	2	3.75	2.5	8.20	5.6	12.70	7.4
10	10.75	5.00	.134	9.5	.165	10.8	.365	20.3	.500	27.3
250	273	127	3.40	4.3	4.20	4.9	9.25	9.1	12.70	12.3
12	12.75	6.00	.156	14	.180	14.4	.375	29	.500	37
300	324	152	3.95	6.3	4.55	6.5	9.55	13	12.70	17

* The shape of these caps conform to the requirements as given in the ASME Boiler and Pressure Vessel Code.

LAP JOINT STUB ENDS

(1) Type A

Schedules 10S & 40S

MSS Length, MSS SP-43

ANSI Length, ASME/ANSI B16.9

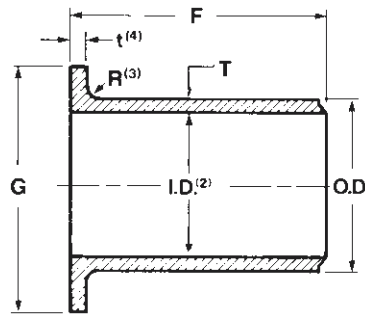

NPS	DN	Nominal Outside Diameter O.D.	⁽⁵⁾ Lap Diameter G	Fillet Radius R ⁽³⁾	Schedule 10S			Schedule 40S				
					Wall Thickness T	MSS		Wall Thickness T	MSS		ANSI	
						Length F	Approx. WT.		Length F	Approx. WT.	Length F	Approx. WT.
1/2	15	.84	1.38	0.12	.083	2.00	.17	.109	2.00	.25	3	.30
		21	35	3	2.11	51	.08	2.75	51	.11	76	.14
3/4	20	1.05	2.69	0.12	0.83	2.00	.20	.113	2.00	.35	3	.40
		27	43	3	2.10	51	.09	2.85	51	.16	76	.18
1	25	1.32	2.00	0.12	.109	2.00	.30	.133	2.00	.40	4	.65
		33	51	3	2.75	51	.14	3.40	51	.18	102	.29
1 1/4	32	1.66	2.50	0.19	.109	2.00	.45	.140	2.00	.60	4	.90
		42	64	5	2.75	51	.2	3.55	51	.27	102	.41
1 1/2	40	1.90	2.88	0.25	.109	2.00	.55	.145	2.00	.85	4	1.25
		48	73	6	2.75	51	.25	3.70	51	.38	102	.56
2	50	2.38	3.62	0.31	.109	2.50	.85	.154	2.50	1.20	6	2.20
		60	92	8	2.75	64	.38	3.90	64	.5	152	1
2 1/2	65	2.88	4.12	0.31	.120	2.50	1.05	.203	2.50	1.75	6	3.45
		73	105	8	3.05	64	.47	5.15	64	.8	152	1.6
3	80	3.50	5.00	0.38	.120	2.50	1.61	.216	2.50	2.50	6	4.70
		89	127	10	3.05	64	.72	5.50	64	1.1	152	2.1
3 1/2	90	4.00	5.50	0.38	.120	3.00	2.07	.226	3.00	3.25	6	5.65
		102	140	10	3.05	76	.93	5.75	76	1.5	152	2.6
4	100	4.50	6.19	0.44	.120	3.00	2.52	.237	3.00	4.00	6	6.7
		114	157	11	3.05	76	1.1	6.00	76	1.8	152	3
5	125	5.56	7.31	0.44	.134	3.00	3.5	.258	3.00	5.60	8	11.7
		141	186	11	3.40	76	1.6	6.55	76	2.5	203	5.3
6	150	6.62	8.50	0.50	.134	3.50	4.8	.280	3.50	8.25	8	15.2
		168	216	13	3.40	89	2.2	7.10	89	3.7	203	7
8	200	8.62	10.62	0.50	.148	4.00	7.7	.322	4.00	13.0	8	23.0
		219	270	13	3.75	102	3.5	8.20	102	5.9	203	10.4
10	250	10.75	12.75	0.50	.165	5.00	12.1	.365	5.00	23.0	10	40.0
		273	324	13	4.20	127	5.5	9.25	127	10	254	18
12	300	12.75	15.00	0.50	.180	6.00	18.0	.375	6.00	33.0	10	49.0
		324	381	13	4.55	152	8.1	9.55	152	15	254	22

1. Type A Stub Ends are used with Lap Joint Flanges.

Type B Stub Ends for use with Slip-on Flanges, available on request.

2. For inside diameter (I.D.) refer to page 16.

3. Nominal and maximum radius.

4. The minimum lap thickness "t" shall not be less than nominal pipe wall thickness T.

5. Nominal and maximum diameter.

For dimensional tolerances, refer to page 5.

INCHES	POUNDS
MILLIMETRES	KILOGRAMS



DIMENSIONS OF WELDED & SEAMLESS STAINLESS STEEL PIPE ASME/ANSI B36.19M

NPS DN	Outside Diameter All Schedules	Inside Diameter				Nominal Wall Thickness			
		Schedule 5S	Schedule 10S	Schedule 40S	Schedule 80S	Schedule 5S	Schedule 10S	Schedule 40S	Schedule 80S
1/2	.840	.710	.674	.622	.546	.065	.083	.109	.147
15	21.35	18.00	17.10	15.80	13.90	1.65	2.10	2.75	3.75
3/4	1.050	.920	.884	.824	.742	.065	.083	.113	.154
20	26.65	23.35	22.45	20.95	18.85	1.65	2.10	2.85	3.90
1	1.315	1.185	1.097	1.049	.957	.065	.109	.133	.179
25	33.40	30.10	27.85	26.65	24.30	1.65	2.75	3.40	4.55
1 1/4	1.660	1.530	1.442	1.380	1.278	.065	.109	.140	.191
32	42.15	38.85	36.65	35.05	32.45	1.65	2.75	3.55	4.85
1 1/2	1.900	1.770	1.682	1.610	1.500	.065	.109	.145	.200
40	48.25	44.95	42.70	40.90	38.10	1.65	2.75	3.70	5.10
2	2.375	2.245	2.157	2.067	1.939	.065	.109	.154	.218
50	60.35	57.00	54.80	52.50	49.25	1.65	2.75	3.90	5.55
2 1/2	2.875	2.709	2.635	2.469	2.323	.083	.120	.203	.276
65	73.05	68.80	66.95	62.70	59.00	2.10	3.05	5.15	7.00
3	3.500	3.334	3.260	3.068	2.900	.083	.120	.216	.300
80	88.90	84.70	82.80	77.95	73.65	2.10	3.05	5.50	7.60
3 1/2	4.000	3.834	3.760	3.548	3.364	.083	.120	.226	.318
90	101.60	97.40	95.50	90.10	85.45	2.10	3.05	5.75	8.10
4	4.500	4.334	4.260	4.026	3.826	.083	.120	.237	.337
100	114.30	110.10	108.20	102.25	97.20	2.10	3.05	6.00	8.55
5	5.563	5.345	5.295	5.047	4.813	.109	.134	.258	.375
125	141.30	135.75	134.50	128.20	122.25	2.75	3.40	6.55	9.55
6	6.625	6.407	6.357	6.065	5.761	.109	.134	.280	.432
150	168.30	162.75	161.50	154.05	146.35	2.75	3.40	7.10	10.95
8	8.625	8.407	8.329	7.981	7.625	.109	.148	.322	.500
200	219.10	213.55	211.55	202.70	193.70	2.75	3.75	8.20	12.70
10	10.750	10.482	10.420	10.020	9.75	.134	.165	.365	.500*
250	273.05	266.25	264.70	254.50	247.65	3.40	4.20	9.25	12.70
12	12.750	12.420	12.390	12.000	11.75	.156	.180	.375*	.500*
300	323.85	315.45	314.70	304.80	298.45	3.95	4.55	9.55	12.70

* These do not conform to ASME/ANSI B36.10M.

CATALOGUE SECTION 11

The suffix "S" in the Schedule Number is used to differentiate B36.19M pipe from pipe of B36.10M.

Although great care has been taken in compiling the information contained in this catalogue, CCTF does not accept responsibility for the consequences of any errors, nor for the effects of any subsequent changes made by the various sources of data.