

## HANGER ATTACHMENTS AND STRUT PRODUCTS

### A U931 Strut Clamp

Fittings unless noted otherwise, are punch-press made from hot rolled, pickled and oiled steel plates, strip or coil, and conform to ASTM specifications A575, A576, A635 or A36.

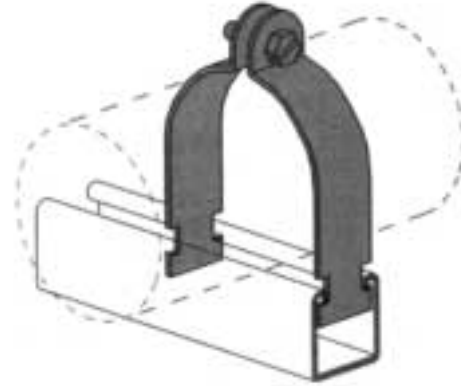

### A U931 STRUT CLAMP for PIPE

| Pipe Size | O.D. Size |       | Material |     | Weight/C |      | Design Load |     | Box Qty |
|-----------|-----------|-------|----------|-----|----------|------|-------------|-----|---------|
|           |           | mm    | Gage     | mm  | Lbs.     | kg   | Lbs.        | kN  |         |
| 3/8       | .675      | 17.1  | 16       | 1.5 | 10       | 4.5  | 400         | 1.8 | 100     |
| 1/2       | .840      | 21.3  | 16       | 1.5 | 11       | 5.0  | 400         | 1.8 | 100     |
| 3/4       | 1.050     | 26.7  | 14       | 1.9 | 15       | 6.8  | 600         | 2.7 | 100     |
| 1         | 1.315     | 33.4  | 14       | 1.9 | 17       | 7.7  | 600         | 2.7 | 100     |
| 1-1/4     | 1.660     | 42.2  | 14       | 1.9 | 19       | 8.6  | 600         | 2.7 | 100     |
| 1-1/2     | 1.900     | 48.3  | 12       | 2.7 | 29       | 13.2 | 800         | 3.6 | 100     |
| 2         | 2.375     | 60.3  | 12       | 2.7 | 34       | 15.4 | 800         | 3.6 | 100     |
| 2-1/2     | 2.875     | 73.0  | 12       | 2.7 | 40       | 18.1 | 800         | 3.6 | 100     |
| 3         | 3.500     | 88.9  | 12       | 2.7 | 47       | 21.3 | 800         | 3.6 | 100     |
| 3-1/2     | 4.000     | 101.6 | 11       | 3.0 | 62       | 28.1 | 1000        | 4.4 | 100     |
| 4         | 4.500     | 114.3 | 11       | 3.0 | 67       | 30.4 | 1000        | 4.4 | 100     |
| 5         | 5.563     | 141.3 | 11       | 3.0 | 80       | 36.3 | 1000        | 4.4 | 50      |
| 6         | 6.625     | 168.3 | 10       | 3.4 | 102      | 46.3 | 1000        | 4.4 | 1       |
| 8         | 8.625     | 219.1 | 10       | 3.4 | 130      | 59.0 | 1000        | 4.4 | 1       |

